

MOTOR POOL MESSENGER

Military Transport Association - North Jersey

May 1994

CALENDAR:

5/9 - Meeting, September's, 8 p.m. as usual

5/14 - Picatinny Parade, 9 a.m.

5/19-22 - Aberdeen Rally, The BIG Spring season opener!

5/30 - Parades - (1) Bloomfield, contact Tom Hauck. (2) West Caldwell, 9 a.m.

6/4-5 - Reading, PA - Air Museum Show.

6/4 - Parade - Whippany, probable, not firm yet.

7/1 - Fairfield, 6 p.m.

7/2 - Montville Parade, tentative.

7/4 - Florham Park parade, 8:30 a.m.

8/10-14 - MVPA National Meeting, Fort Indiantown Gap, PA. We are one of the host chapters. Please be prepared to work as well as enjoy the excitement.

9/11 - Ray Bentley meet, Adams Metal at Ledgewood. Details later.

9/23-25 - MTA Rally, Warren County Fairgrounds. Participation by all will be needed.

NEW MEMBERS: (Add to your roster)

Craig Model, HR-1 Box 212 Jersey Ave., Greenwood Lake, N.Y. 10925, 201-208-9654

Alexander Tucciarone -(no address supplied)

For Sale:

M-37, 1951. Lots of new parts, all new canvas, good title. Jack White 908-647-3367

1944 Ford Jeep - Body shot, but complete with bows. Extra frame and axle assemblies included. Four combat rims, three engines, one rebuilt never started, other two are take-outs. Brand new body tub also. All for \$3500. Call Big Lou at 201-887-0771, 5:30-9:30 week nights.

M170 ambulance kit. Needs TLC. John Marko, 908-766-3784.

Two 3/4 ton Carryalls (one \$3750, one \$2500) or both \$5000. Both have good bodies to restore. Tire chain repair cross chains with V-bars, \$1 each. 600-16 chains, \$15/pair. NOS hot water heater, complete kit for M-38, \$500. Call Dick Hirsch 914-351-4609, fax 914-351-4262.

Drafting table, non-military. Wood, completely refinished. A beautiful piece of wood. Raises, lowers, tilts. \$100. Pete Berendsen 201-966-1862

U.S. Army Field Table. Excellent condition. \$20 Harold Ratzburg. 201-887-2574.

Wanted:

Hot water heater for M35 2 1/2 ton truck; tracks or bottom-end parts for Clark airborne bulldozer. Call Doug Stober 201-543-9355.

Jeep accessories, part 3 - We continue with more Power take-off information and accessory controls. Wouldn't some or all of these look neat on your military jeep? How about the propeller shaft guards? Note the hydraulic implement lift. More will be shown about this item in later issues. It is THE vital attachment to power many of the operating accessories.

The 'Jeep' can be tailored

REAR POWER TAKE-OFF

(With center P.T.O., Willys-Overland Kit No. 640726)

(When including pulley drive, Kit No. 646452)

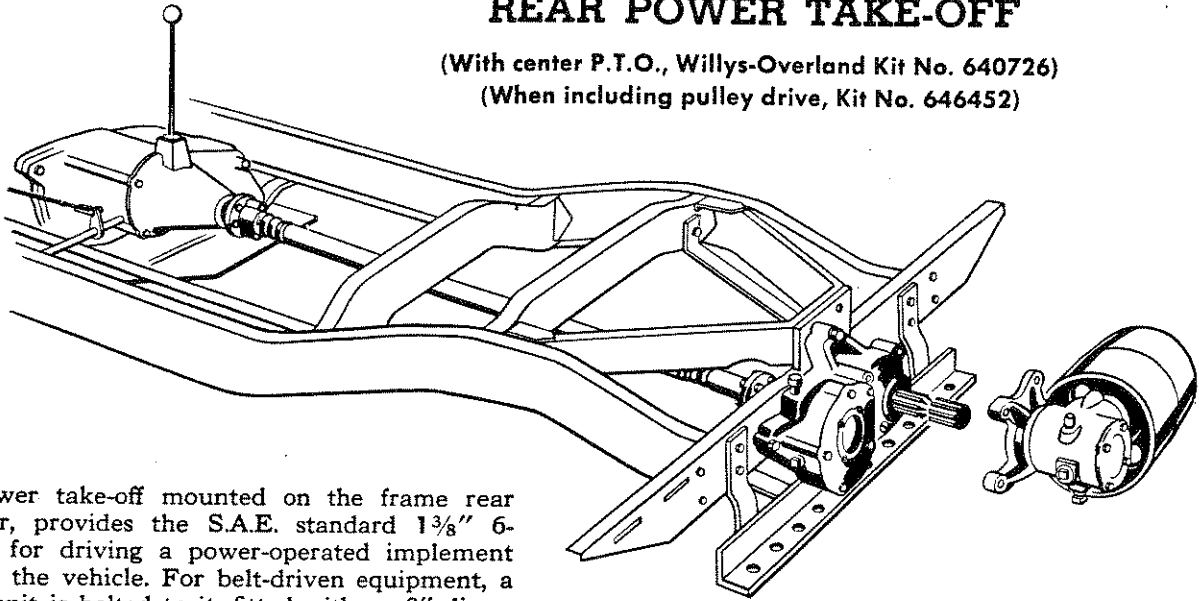

The rear power take-off mounted on the frame rear cross member, provides the S.A.E. standard $1\frac{3}{8}$ " 6-splined shaft for driving a power-operated implement towed behind the vehicle. For belt-driven equipment, a pulley-drive unit is bolted to it, fitted with an 8" diameter pulley with speeds ranging from 255 to 2674 r.p.m., governor controlled.

(Pulley Drive only — W.O. Kit No. 644193)

HYDRAULIC IMPLEMENT LIFT

The "Monroe" hydraulic implement lift now made available by Willys-Overland Motors is the culmination of years of development and experience. It embodies many special features including:

1. Ease of attachment of implements, "3-point system" is used.
2. Quick upward or downward action.
3. Double action hydraulic cylinder for either up or down pressure on the implement. Fingertip control at driver's seat.
4. Good "trailing" or following of plows and other implements.
5. Simplicity and ease of adjustment which can be made from the driver's seat.
6. Easy installation or removal of the lift on the 'Jeep'.
7. Accessibility of all working parts and non-interference with other standard 'Jeep' accessories such as the power take-off and tow bar hitch.

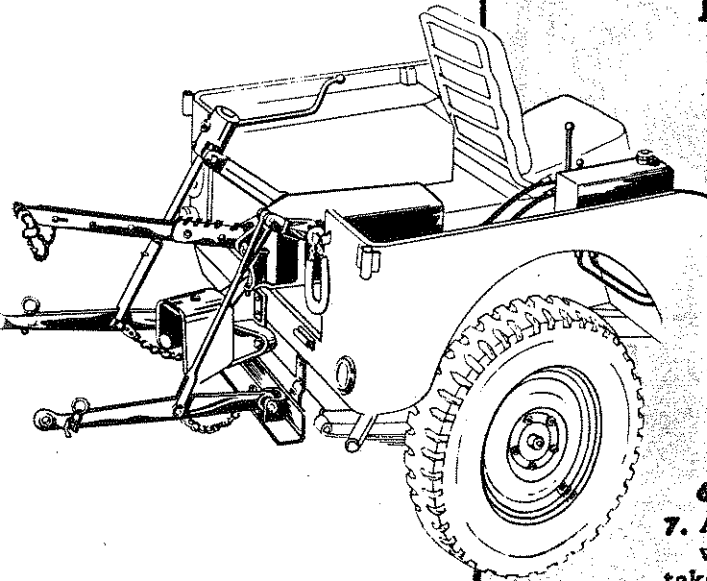

for EVERY job!

FRONT POWER TAKE-OFF

The front power take-off drives from the front end of the crankshaft directly off the engine and provides plenty of war-proven 'Jeep' power for such useful implements as the capstan or drum winch, suction pumps, booster pumps.

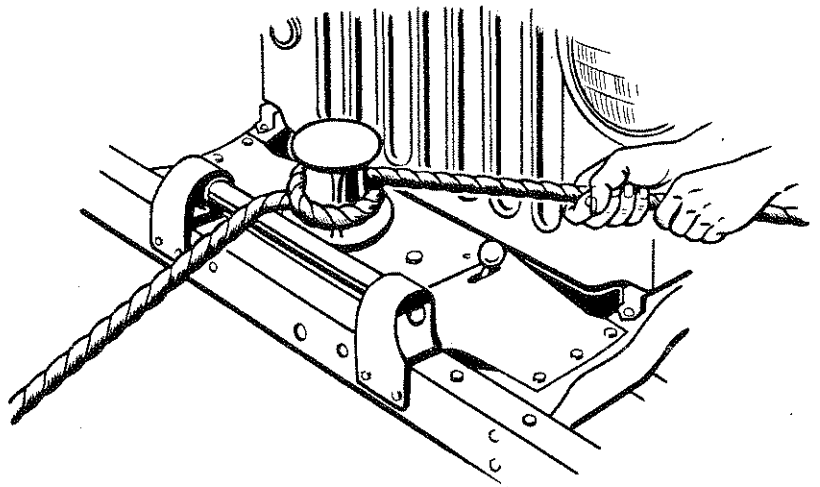

CENTRIFUGAL-TYPE GOVERNOR

(Willys-Overland Kit No. 645313)

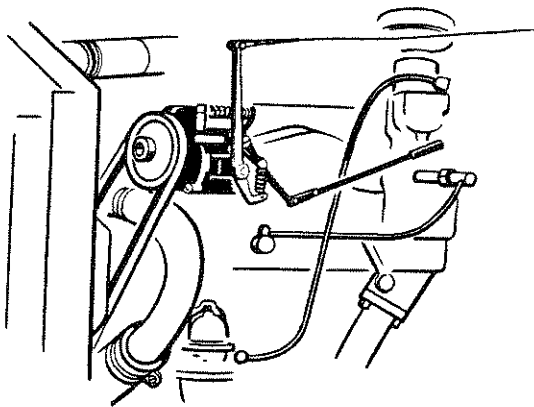

Many farm and industrial operations demand a governor to give precision control of engine speeds. Unit is controlled from driver's seat by control on dash with nine notched positions. Lowest speed is approximately 1000 R.P.M. and each successive notch increases engine speed by 200 R.P.M. until the limit is reached at 2600 R.P.M. These nine different engine speeds in connection with the various transmission and transfer case gear ratios allow 54 controlled forward vehicle speeds.

Definite and valuable protection is gained when these propeller shaft guards are used. Easy to attach, they reduce the chance of grass, hay or weeds matting and bunching up on the forward and rear propeller shafts to cause fire or damage to oil seals. Kit includes full length guard for rear shaft, necessary-length guard for forward shaft and baffle plate.

PROPELLER SHAFT BRUSH GUARDS

(Willys-Overland Kit No. 641760)

